



201 N 5th Ave, Bldg #6
Lebanon, PA 17046
(717) 550-1298

support@HarmonyTurbines.com
<https://HarmonyTurbines.com>

Harmony Turbines Pitch Deck

Industry Clean Technology and Industrial / Energy
IP Patents [US 10,724,502](#) and [US 11,149,715](#)
Stage In Development - Seed Funding Round
Founded August 2020
Staff 6 Full-Time, 1 Part-Time

[Visit our FAQ](#) for answers to our most common questions

Executive Summary

Harmony Turbines is developing leading-edge residential and small-scale wind turbine systems for a better tomorrow! It's clear that the products currently on the market are failing to meet the needs of customers, evidenced by the fact that so few small-scale and residential wind turbines are actually in use today.

We have raised \$3M in Equity Crowdfunding Investments between August 2020 - July 2025, comprising of [\\$404K from 730 investors on WeFunder](#) and [over \\$2.7M from over 2,700 investors on Startengine](#). In exchange for these investments we have given away approximately 30% of the equity in our company, a reasonable trade-off to launch our business.

We anticipate our initial units will be rated at 400w or better in a 25mph wind, with a target cost of about \$5,500 USD each, but that is subject to change as we move into production due to fluctuating prices for raw materials. Our goal is to have an affordable price that covers our costs without taking advantage of our customers, providing a reasonable ROI.

Our products are designed around 4 key points, convenience, ease of use, features and cost. Because of these 4 key design points, we firmly believe that Harmony Turbines will become the next global standard in residential and small scale wind power generation. Our units are beautiful, silent in operation and they pose no danger to people or wildlife.

What Sets Us Apart from the Rest?

The two main ways in which Harmony Turbines will be different from the rest of the small-scale wind turbines on the market today is through the use of our two proprietary patented technologies. Our generator design will handle low wind startup speeds of 1 - 2 mph and eliminate [cogging issues](#) allowing Harmony to scavenge winds that other turbines ignore; while our [furling technology](#) will handle high wind situations allowing Harmony to produce full power right on through events that can disable or even destroy other turbines on the market today.

Patented Furling Technology

Details: Savonius rotor with a full helix twist and ribbed segments with **variable** [cross-sectional exposure](#)

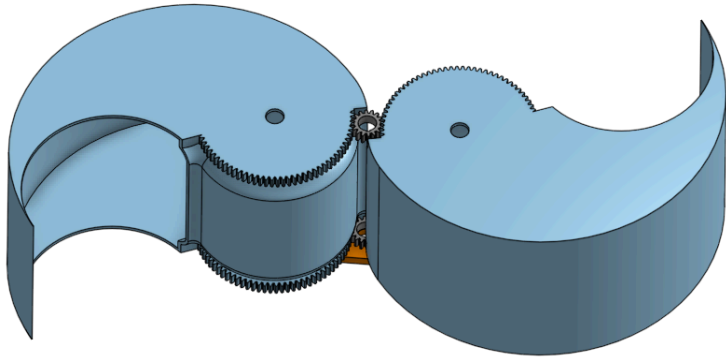

Turbine Scoops Fully Open

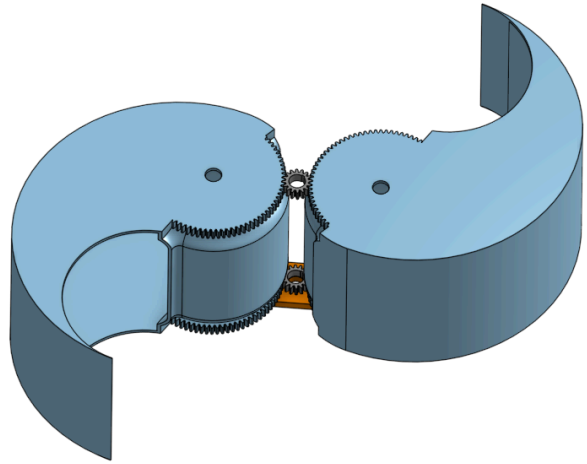

Turbine Scoops Partially Closed

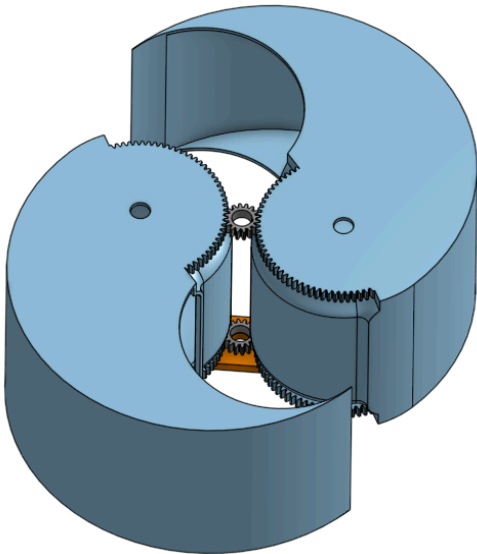

Turbine Scoops Almost Closed



**Image is of the prototype of the product.
Product is still currently under development*

400w Prototype Fully Open



400w Prototype Partly Open



**Images are of the prototype of the product. Product is still currently under development*

Patented Axial Flux Generator

Details: Axial flux [solid core](#) dual pole permanent magnet generator with a **variable** air-gap

Maximum Air-Gap

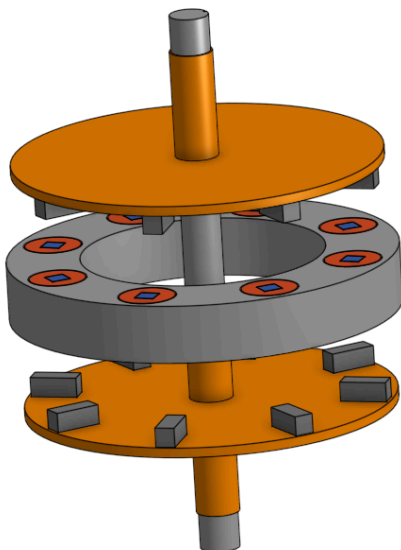

Generator starts with maximum air-gap to avoid [startup cogging](#) and electromagnetic lockup

Medium Air-Gap

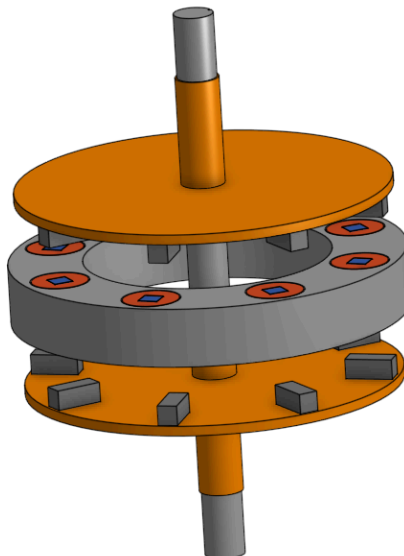

As RPMs increase air-gap is decreased and power production increases

Minimum Air-Gap

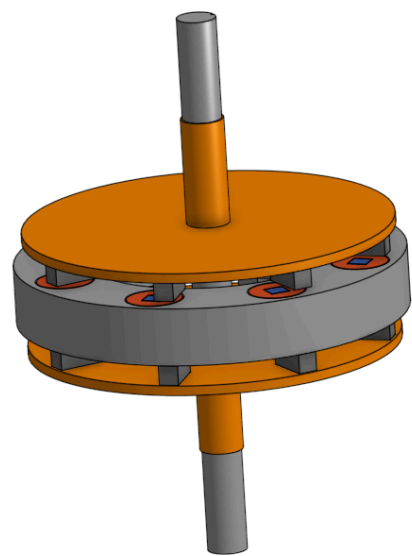

As RPMs reach desired level air-gap is reduced to minimum level for maximum power production

The main challenges still ahead of us are:

- Development of our simplified axial flux generator for our initial market
- Finalizing our turbine scoop geometry to maximize power production
- Finalizing development of our proprietary buck/boost charge controller

The main risks we face are:

- Not acquiring enough funding to finish the development of our product before we go into production
- Cost of production being higher than we anticipate which could increase our retail prices and discourage widespread adoption of our products

We and thousands of other investors, followers and supporters, believe that Harmony Turbines has a bright future ahead if we can overcome these last few remaining challenges.

Financials (as of August 31, 2025)

Funds on-hand : \$269,300 USD

Current Monthly Burn Rate: \$48,300 USD

	2023	2024	2025 (Projected*)	2026 (Projected*)
Carryover	\$474,598	\$893,261	\$384,047	\$1,856,179
Funding Received	\$1,360,955	\$318,868	\$2,181,132	\$0
Revenue	\$24,274	\$39,396	\$27,500	\$275,000
Expenditure	-\$966,567	-\$867,477	-\$736,500	-\$885,000
Gain or Loss	\$893,261	\$384,047	\$1,856,179	\$1,246,179

2025 & 2026 Revenue Driver: Orders for our beta 400w units @ \$5,500ea (5 units in 2025, 50 units in 2026)

*Forward-looking projections cannot be guaranteed

Market Size - Addressability and Adoption Metrics for the U.S.

Estimated: **\$3.46 Billion***

- Addressability
 - Residential homes in place as of 2015 = [22.6 million](#)
 - Boating vessels in place as of 2022 = [11.8 million](#)
 - Recreational Vehicles in place as of 2020 = [11.0 million](#)
- Adoption Rates

	<u>Sales Potential</u>
○ Residential Homes - 3% of 22.6M units	\$ 1.70B*
○ Boating – 5% of 11.8M vessels	\$ 1.48B*
○ RV's – 1% of 11M vehicles	\$ 275M*
○ NOTE: * Based on an estimated \$5,500 per VAWT kit price	

Existing Investors

- Equity Crowdfunding through StartEngine: <https://www.StartEngine.com/Harmony-Turbines>
 - Over \$2,798,000 raised from over 2,700 investors
 - Oct 2022 - March 2023 & Aug 2024 - July 2025
- Equity Crowdfunding through WeFunder: <https://WeFunder.com/Harmony.Turbines>
 - \$404,357 Raised from 730 investors
 - Aug 2020 - March 2021 & Aug 2021 - March 2022

Growth Since Incorporating

- Serious investor backing, \$3M+ raised from our community intermittently from August 2020 - July 2025
- Two fully granted patents [US 10,724,502](#) and [US 11,149,715](#)
- Built and equipped HTHQ (Harmony Turbines Headquarters) a 9,000 square foot, research, development and early production facility, allowing us to fabricate our own parts
- Partnership with [Steel Design Manufacturing](#) for prototyping and early production needs
- One ALPHA stage wind turbine prototype installed on our Headquarters rooftop with plans to install a few more with varying scoop geometries
- Developing our own proprietary simplified axial flux generator, intended to meet our low-RPM requirements with a cost-effective elegant solution
- Developing our own proprietary buck/boost charge controller that will meet our unique requirements
- Testing and evaluating 150+ scoop geometries in our on-site wind tunnel

Team

Christopher Moore

President/CEO (W2 Employee)

<https://www.linkedin.com/in/creatingmoore/>

Entrepreneur, inventor, tinkerer working with Clean Energy technologies for over 20 years doing everything that I can to make the world and our lives better than they are today. Challenges never scare me; closed-minded people scare me!



Cheryl Moore

Secretary & Treasurer/COO (W2 Employee)

<https://www.linkedin.com/in/cheryl-m-8b273b1b/>

Cheryl has 20+ years of office, Human Resources and IT and analytics experience. She has a Masters Degree in Information Systems, with a Bachelors Degree in Human Resources Management. Having owned 2 companies of her own, she's excited to apply her many skills to Harmony Turbines.



Jeremy Good

CAM / CNC Machining Lead (W2 Employee)

Jeremy is a CNC Programmer with over 20 years of experience in the trade. Constantly exploring new ideas and methods, he is always ready for the next challenge. He is looking forward to exploring the infinite possibilities at Harmony.



Dallas Heblow

Shop Assistant (W2 Employee)

Dallas has a wide variety of knowledge and experience, both in and out of the shop, ranging from metalworking to digital media. Dallas brings an open minded mentality and a drive to find a solution to any problem. Outside of work he enjoys spending time with friends and family, playing strategy games, and traveling to new places and seeing new things.



Jeshwanth Dharna**Electronics Engineer** (FT Contractor)

Jeshwanth holds a M.S. in Electrical Engineering and brings strong expertise in embedded systems, firmware development, and hardware integration. He is helping lead efforts in charge controller development, performance monitoring, and electronics troubleshooting. He enjoys exploring new places, taking on new adventures, and staying up-to-date with emerging technologies.

**Sree Vidya Jagatap****Electronics Engineer** (FT Contractor)

Sree Vidya has a strong academic foundation and practical industry experience. Her most recent work involved problem-solving, optimizing designs, and collaborating closely with teams to bring creative ideas into functional, real-world solutions. Beyond her professional role, she has a passion for travel, enjoys discovering new experiences, and keeps herself engaged with the latest trends in technology and engineering advancements.

**Hannah Salmeron****Communications Specialist** (PT Contractor)

Hannah is a proud wife and mother of three young and active boys. She is thrilled to embark on this new adventure with Harmony. With a strong commitment to personal and professional growth, she is eager to expand her skill set and contribute to the ongoing success of the company.



Robert Jonasar**CAD Design Engineer** (Consultant)

Robert started his first (and only) job, as a fresh faced 20y old back in 1984 as a wireman. Over the years he has done production, product development and customer support. In the last 15 years he has been doing CAD design for various customers.

**Robert Hadfield****Strategic & Business Development Advocate** (Business Mentor)

<https://www.linkedin.com/in/robertwhadfield/>

Executive Management, Global and Domestic Strategic Planning, Product Development, New Business Development, International Sales and Marketing, and Forming Strategic Alliances.

